



# Powerful and Energy Efficient Performance



**AMERIGO**

*EOT Crane & Hoist Experts*



## ABOUT US

AMERIGO MANUFACTURES VARIOUS TYPES OF OVERHEAD TRAVELLING CRANES, SPARES, AND VARIOUS TYPES OF MATERIAL HANDLING EQUIPMENT. OUR PRODUCTS ARE EXPORTED GLOBALLY. THE MANUFACTURING UNIT IS LOCATED IN AHMEDABAD - INDIA. WE ARE EQUIPPED WITH LATEST MACHINERIES AND MODERN TECHNOLOGY MANUFACTURING HIGH QUALITY RANGE OF OVERHEAD CRANES AS PER VARIOUS APPLICATIONS.

WE PROVIDE ONE-STOP SOLUTIONS FOR ALL TYPES OF CRANE REQUIREMENTS AS PER CLIENT'S REQUEST. THE CRANES ARE MANUFACTURED AS PER IS STANDARDS. WE MANUFACTURE CRANE CONSIDERING THE PRODUCT PERFORMANCE AND ACCURACY TO SUIT THE SPECIFIC NEEDS OF OUR CUSTOMERS AS PER THEIR APPLICATION. OUR PRODUCTS ARE TAILOR-MADE PRODUCTS WITH VARIOUS CAPACITIES.

## VISION & MISSION

OUR PHILOSOPHY IS TO BUILT THE BEST PRODUCTS THE WAY THEY SHOULD BE BUILT AND OFFER THEM AT COMPETITIVE PRICES FOR THE BROAD MARKET. OUR IN-HOUSE DESIGN, MANUFACTURING AND TESTING FACILITY ARE A TESTIMONY TO OUR COMMITMENT TOWARDS CUSTOMER'S SUCCESS. WITH THIS WE FOCUS ON CONTROLLING COSTS, ENSURING COMPONENT AVAILABILITY AND ON TIME DELIVERIES.

## Product Range



**DOUBLE GIRDER  
E.O.T. CRANE**



**SINGLE GIRDER  
E.O.T. CRANE**



**STEEL MILL DUTY  
E.O.T. CRANE**



**UNDER SLUNG  
E.O.T. CRANE**



**SEMI GANTRY  
E.O.T. CRANE**



**GANTRY / GOLIATH  
E.O.T. CRANE**



**JIB CRANE**



**ELECTRIC WIRE  
ROPE HOIST**



**TRANSFER  
TROLLEY**



**C-HOOK FOR COIL  
LOADING & UNLOADING  
SLAB BUNDLE HANDLER**



**INDUSTRIAL  
GOODS LIFE**



**INDUSTRIAL  
SHADE**



**DOUBLE GIRDER  
E.O.T. CRANE**  
Capacity Upto 100 Tons



The overhead crane having two main bridge girders is known as double girder EOT/HOT Cranes. By virtue of its structural design it is sturdy and robust in construction. Double Girder construction offers aesthetic look and also gives feel of safety while handling heavy loads. Normally it is used to handle heavy load or heavy duty (continues) application in foundry and steel plants. The double girder overhead cranes are manufactured low medium & high capacity ranging upto 100 Tons capacity depending on type of application.

**Product Highlights**

- Longer Life
- Less Maintenance
- Sturdy in Design
- Wider Span
- Favorite for Special Applications

**Applications**

- ▶ Wire Mill
- ▶ Mold Handling
- ▶ Metal Storage
- ▶ Fabrication
- ▶ Stamping
- ▶ Coil Handling





## STEEL MILL HEAVY DUTY CRANE

Capacity Upto 50 Tons



Steel Mill Duty Crane is extensively used for lifting application in various steel mill and rolling mill industries where requirement is for high-speed, high-capacity ladle, metal charging. These cranes are designed under different Indian standard (IS) as per IS-4137 standard. This crane is fabricated under the strict supervision of experienced and diligent professionals in order to meet the Indian International quality standards. Our offered crane is stringently checked on criteria like performance. In order to meet the exact requirement of client, this Steel Mill Duty Crane is fabricated in various models and specifications.

### Product Highlights

- Centralized Lubrication
- Heavy Duty Gearbox
- Fail Safe Brakes
- Safety Limit Switches
- Longer Life

### Applications

- ▶ Rolling Mills
- ▶ Liquid Metal Handling
- ▶ Forging Industries
- ▶ Billet Metal Industries
- ▶ Casting Industries





## GANTRY / GOLIATH E.O.T. CRANE

Capacity Upto 50 Tons



Gantry Crane or Goliath Crane or Portal Crane, name by which it is generally known, is the most ideal material handling equipment to handle heavy loads in open yards. It is generally desired for outdoor application. The name Goliath indicates its huge load capacity and giant structure built up. However, it sometimes finds its place in assembly shop of engineering unit Specifically in Automatic Unit.

### Product Highlights

- Suitable for Open Areas
- Extensive Cover of The Floor Areas
- Master Controller / Remote / Pendant
- Cable Reeling Drum
- Favorite in Marble Industries

### Applications

- ▶ Ship & Steel Yard
- ▶ Open Yard Storage
- ▶ Pipe Industries
- ▶ Granite & Marble Industries



## SEMI GANTRY E.O.T. CRANE

Capacity Upto 50 Tons



Semi Gantry Cranes are a cost-effective alternative wherever the installation of bridge cranes is impractical due to a need for a raised runway structure. They are also an ideal supplement to bridge crane at the workstation level. This crane can be used for indoor or outdoor application. Single Girder Semi Gantry Cranes generally used for load up to 15 TON and Double Girder Semi Gantry Cranes can be used for load up to 50 TON capacity cranes. This crane can be controlled by pendent traveling stations or radio remote controls.

### Product Highlights

- Wider Span
- Fail Safe Brake
- Indoor or Outdoor Operation
- Pendent or Remote Control Operations
- Extensive Cover of The Floor Area

### Applications

- ▶ Outdoor Workshop
- ▶ Outdoor Stock Yard
- ▶ Warehouses
- ▶ Fabrication Shop
- ▶ Marble & Stone Ind.



**AMERIGO**

## SINGLE GIRDER E.O.T. CRANE

Capacity Upto 10 Tons



The Crane which are having one main Bridge Girder are known as Single Girder Cranes. Main feature of this crane are main bridge girder, end carriages and hoisting unit either electrically operated hoist or manual operated Chain pulley block as the case may be. Being light in structure, it is most ideally suited for light industrial application. Being cost-effective, Single Girder Crane is most favorite in small and medium scale Industries.

### Product Highlights

- Direct Mounting Gearbox
- Light Structure
- Longer Life
- Cost Effective
- Easy in Maintenance
- Pendant & Radio Remote
- Control Operation

### Applications

- ▶ Warehouse
- ▶ Stock Yard
- ▶ Machine Shop
- ▶ Assembly Shop
- ▶ Store Rooms

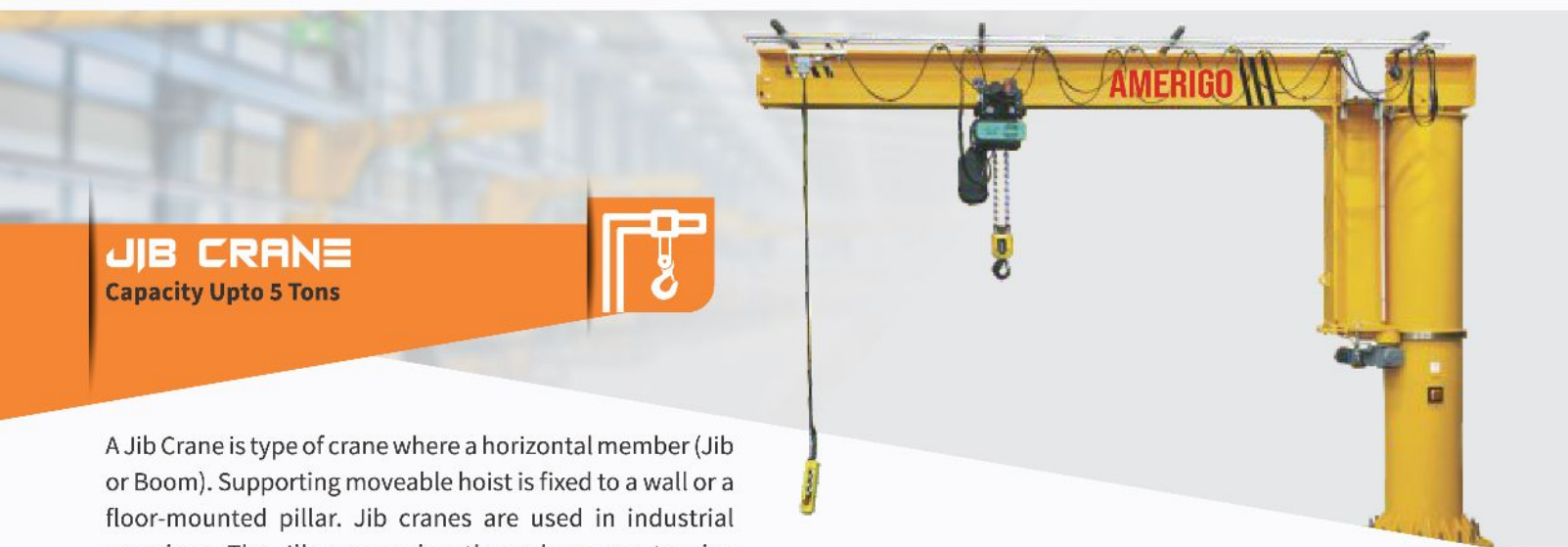

## JIB CRANE

Capacity Upto 5 Tons



A Jib Crane is type of crane where a horizontal member (Jib or Boom). Supporting moveable hoist is fixed to a wall or a floor-mounted pillar. Jib cranes are used in industrial premises. The Jib may swing through an arc to give addition lateral movement or be fixed. Jib crane are designed and manufactured for specific application, though it has limitation of working area for particular applications. It proves most useful in assembly area of small machine like pumps, electric motor, vehicle assembly etc. For example loading and unloading facility for material in open yard fir loading and unloading of special purpose machine on material handling unit for CNC machine kept in clean room.

### Product Highlights

- Lighter in Weight
- Less Maintenance
- Suitable for Critical Shifting
- Rotation upto 360°
- Easy Mobility

### Applications

- ▶ Building Construction
- ▶ Repair Shop
- ▶ Tool Rooms
- ▶ Unloaders
- ▶ Stock Yard



## INDUSTRIAL SHEDS



We have expertise in designing, manufacturing and exporting conventional and PEB type sheds to our valued clients. We fabricate these sheds using advance technology ensuring qualitative product at customer's end. Our skilled engineers are capable of providing the desired product to valued customer in strict compliance with their demands.

Our company is reckoned for designing, manufacturing, supplying and exporting premium quality industrial sheds, godown sheds and storage sheds. We build these sheds using quality raw material that we procure from reliable vendor-base ensuring longer functional life. Our professionals use high-grade tools and equipments for fabrication and using innovative approaches they fabricate these qualitative sheds for our valued patrons. Our technicians enabled us to provide to the desired product exactly as per the customer's given specification within stipulated time.



### Product Highlights

- Sturdily Constructed
- Space Efficient Design
- Possess Anti-corrosive & Abrasive Properties
- Can Withstand Adverse Temperatures
- Spacious Design
- Furnished with Required Safety Features
- High Durability
- Ability to Withstand Extreme Weather Conditions
- High Structural Strength
- Corrosion Resistant Finishing
- Wear & Tear Resistant
- Prevents Stored Items from Adverse Temperature & Weather Conditions

### Applications

- ▶ Ware House Shed
- ▶ Cold Storage
- ▶ Factory Sheds
- ▶ Fabrication
- ▶ Prefabricated Shed
- ▶ Shed Steel Structure
- ▶ Workshops
- ▶ Aircraft Hangars
- ▶ Anything & Everything you need a Large, Strong Shed.



# OTHER PRODUCTS

## C-HOOK FOR CONTAINER STUFFING



## SLAB BUNDLE HANDLER



## C-HOOK FOR COIL LOADING & UNLOADING



## END CARRIAGE





**ELECTRIC HOIST**



**INDUSTRIAL GOODS LIFT**



**CRAB UNIT**



**POWER ELECTRIC WINCH**

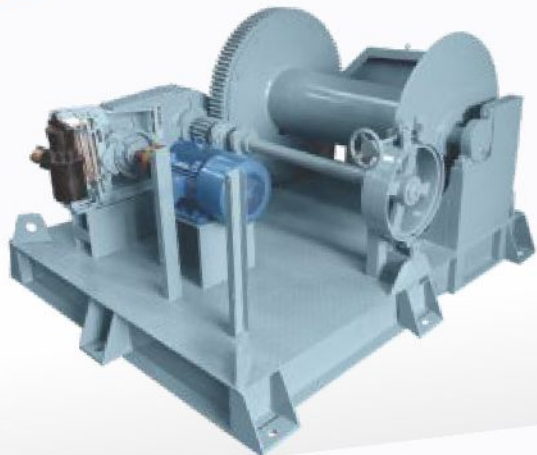

**ELECTRIC TRANSFER TROLLEY**



**ELECTRIC TRANSFER TROLLEY**



GEAR BREAK DRUM



L-BLOCK WHEEL



GEAR BOX



CRANE DUTY MOTOR



CABLE TROLLEY



ELECTRO HYDRAULIC THRUSTER BRAKE

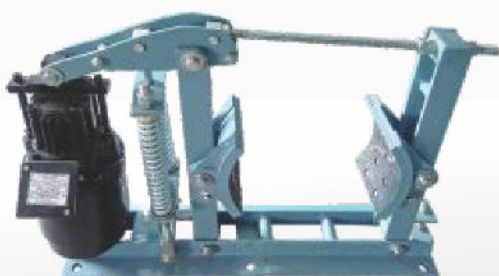

ELECTROMAGNETIC AC DISC BRAKE



DC DISC BRAKE



STEEL WIRE ROPE SLINGS



WIRE ROPE



BRAKE SHOE WITH LINER CAST IRON



DSL SHROUDED BUS BAR SYSTEM

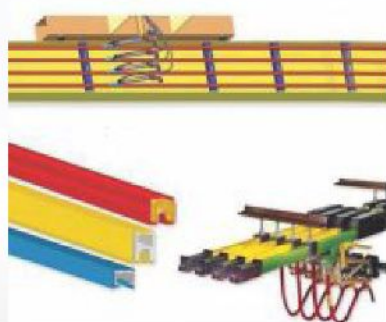

C-RAIL FESTOON SYSTEM



BUS BAR



**VFD BASED  
CRANE CONTROL PANEL**



**RESISTANCE BOX  
S.S. 304 PUNCH GRID TYPE**



**MASTER CONTROLLER**



**DYNAMIC BRAKING  
RESISTOR**



**PENDANT**

METAL BODY RIGID PVC BODY



**LIMIT SWITCH  
ROTARY GEAR**



**COUNTER WEIGHT**



**LEVER TYPE**



**CROSS BAR**

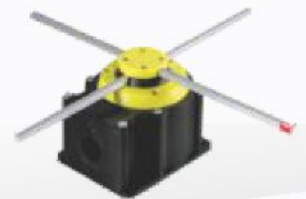

**SWITCH GEAR**



**WIRELESS RADIO  
REMOTE CONTROL SYSTEM**



**VARIABLE FREQUENCY  
DRIVE**



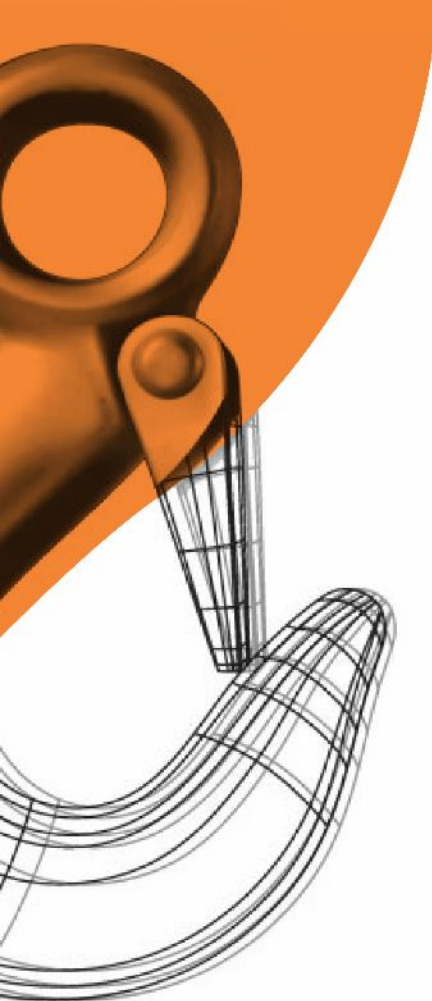

## Our Valuable Clients



## AMERIGO EXPORTS PVT LIMITED

5B ,Prerna Soc.-1, Parasnagar, Isanpur, Ahmedabad-382443, Gujarat - INDIA.

Factory: A2-66, Nr. Mayur Dye Chem, Phase-2, GIDC, Vatva, Ahmedabad-382445, Gujarat - INDIA

Mobile : +91-9925362065

Tel: +91-7567772304

Whatsapp / Wechat: +91-9925362065

Mail: sales@amerigo-crane.com | amerigoexports@rediffmail.com

Visit us : www.amerigo-crane.com

